

EATHORPE

BATTERY

Community Information Booklet

May 2023

NEOEN

 eathorpebattery.com.au

 Joanna Murphy, Project Manager

 contact@eathorpebattery.com.au

 1800 966 020



CONTENTS

About Neoen	1
Our Big Batteries	2
Neoen owned & operated	5
Project facts & figures	6
What can a big battery do?	7
New England REZ	8
Choosing the site	9
Proposed project layout	10
Proposed battery layout	11
Project lifecycle	12
Community benefit-sharing	13
Neoen Learning Hub	13
Frequently asked questions	14



GLOBALLY

The company is headquartered in Paris, France, and has six Australian offices – in Brisbane, Sydney, Canberra, Melbourne, Adelaide and Perth.

We operate across renewable energy technologies including solar, wind and storage in Europe, the Americas, Africa, and Australia.

Neoen's total capacity in operation and under construction is currently 6.6 GW and we are aiming for 10 GW by the end of 2025.

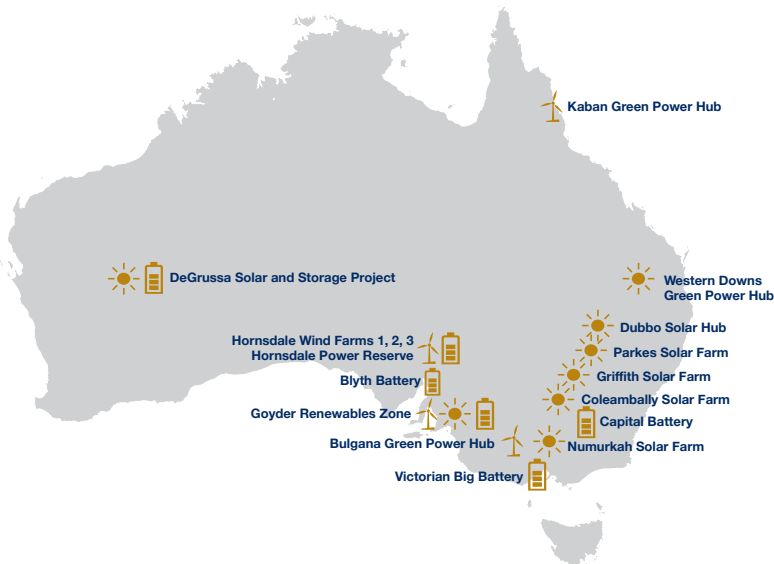
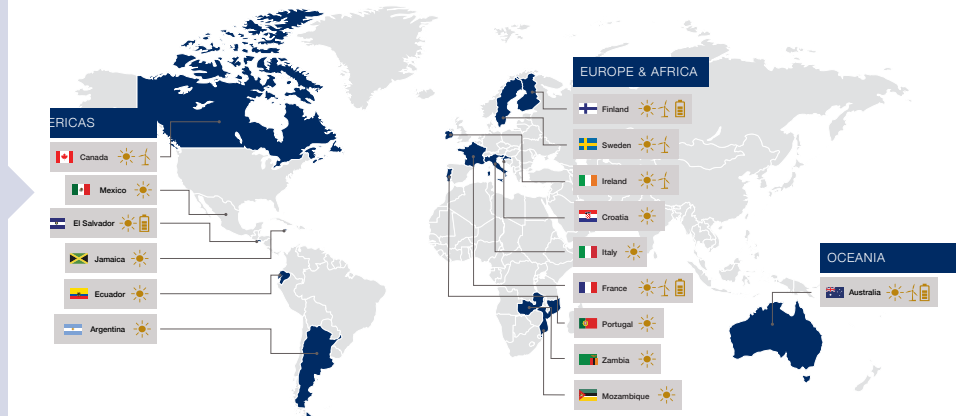

LOCALLY

Neoen Australia began operations in 2012. Over the last eleven years, the company has initiated the development of close to 3 GW of solar, wind and storage projects through organic growth, local partnerships and strategic acquisitions.



Neoen produce green electricity from renewable sources such as sunlight and wind using mature, tried and tested technologies. We are also leaders in energy storage.

WORLD'S FIRST BIG BATTERY HORNSDALE POWER RESERVE



FIRST STAGE
TOOK LESS THAN
SIX MONTHS TO
BUILD

- 150 MW Lithium-ion battery located next to Hornsdale Wind Farm
- Owned and operated by Neoen
- Installed and maintained by Tesla

- Provides grid stability services
- Saved SA energy consumers over \$150 million in its first two years
- Now testing grid scale inertia services in a world-first



REDUCES RISK
OF BLACKOUT
IN SOUTH
AUSTRALIA



AUSTRALIA'S LARGEST BIG BATTERY VICTORIAN BIG BATTERY



- Up to 300 MW Lithium-ion battery located next to Moorabool substation in Geelong
- Owned and operated by Neoen
- Installed and maintained by Tesla



TOOK LESS
THAN TWELVE
MONTHS TO
BUILD



- Enabling more wind and solar, now the cheapest forms of power
- Allowing more power to flow into the state, increasing competition and pushing electricity prices down
- Helping to avoid blackouts and the associated costs

CONTRIBUTING
TO VICTORIA'S
40%
**RENEWABLES
TARGET BY
2025**



CAPITAL BATTERY PROVIDING AGL WITH A PIONEERING VIRTUAL BATTERY SOLUTION

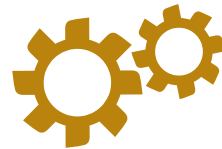

ON TRACK TO
START
OPERATING
IN 2023

- Up to 100 MW / 200 MWh Lithium-ion battery located next to the Queanbeyan substation near Canberra
- Owned by Neoen with technology from Doosan
- Debt financing provided by Clean Energy Finance Corporation and Infradebt

- World first Virtual Battery contract with AGL for 70 MW
- AGL can virtually charge and discharge the battery at any time over 5-min trading intervals
- Neoen's third big battery in Australia



POWERFUL
ENOUGH TO MEET
20% OF ACT'S
SUMMER PEAK
DEMAND



WE OWN & OPERATE OUR PROJECTS

Eathorpe Battery

The Eathorpe Battery will be managed from Neoen's 24/7 Operational Control Centre in Canberra, which currently operates our 14 existing projects across Australia. This office coordinates with local maintenance contractors for safe, effective and compliant operations.

Neoen's Portfolio

Neoen develops renewable energy projects to own and operate them – not to on-sell them. With over 2.5GW of operating projects connected to Australia's National Electricity Market (NEM), our asset and operations team play an important role in managing our power plants.



Our Operational Control Centre oversees our interactions with the National Electricity Market: a wholesale electricity market which spans the eastern and south-eastern coast of Australia.

The market works as a pool or spot market, where power supply and demand are instantly matched via a centrally coordinated dispatch process overseen by the Australian Energy Market Operator.

FACTS & FIGURES



100MW
power capacity

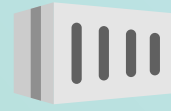

200MWh
energy storage

Stores an industrial amount of energy,
discharges quickly on demand

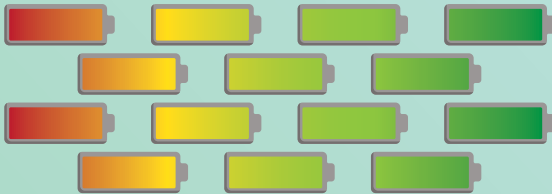

14,000x
more capacity than a household battery

BATTERY TECHNOLOGY

Battery packs are enclosed in custom designed, dust and waterproof 'cabinets' made of galvanised steel. Cabinet colour is white or light coloured to assist with heat management and each cabinet has its own internal thermal management system.

Will conform to electricity industry standards

Will use an industrial inverter to convert DC power to AC when discharging (vice versa when charging)

Battery cabinet

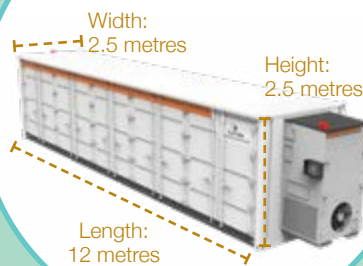

Likely to be lithium-ion battery packs enclosed in steel cabinets, similar to shipping containers

Will meet all safety and bushfire risk requirements

Battery brand to be determined

Inverter

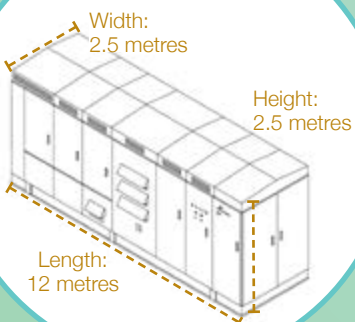

Inverters are made from galvanised steel, and may exist as one single 20ft container or a few outdoor cabinets on concrete slabs.

WHAT CAN A BIG BATTERY DO?

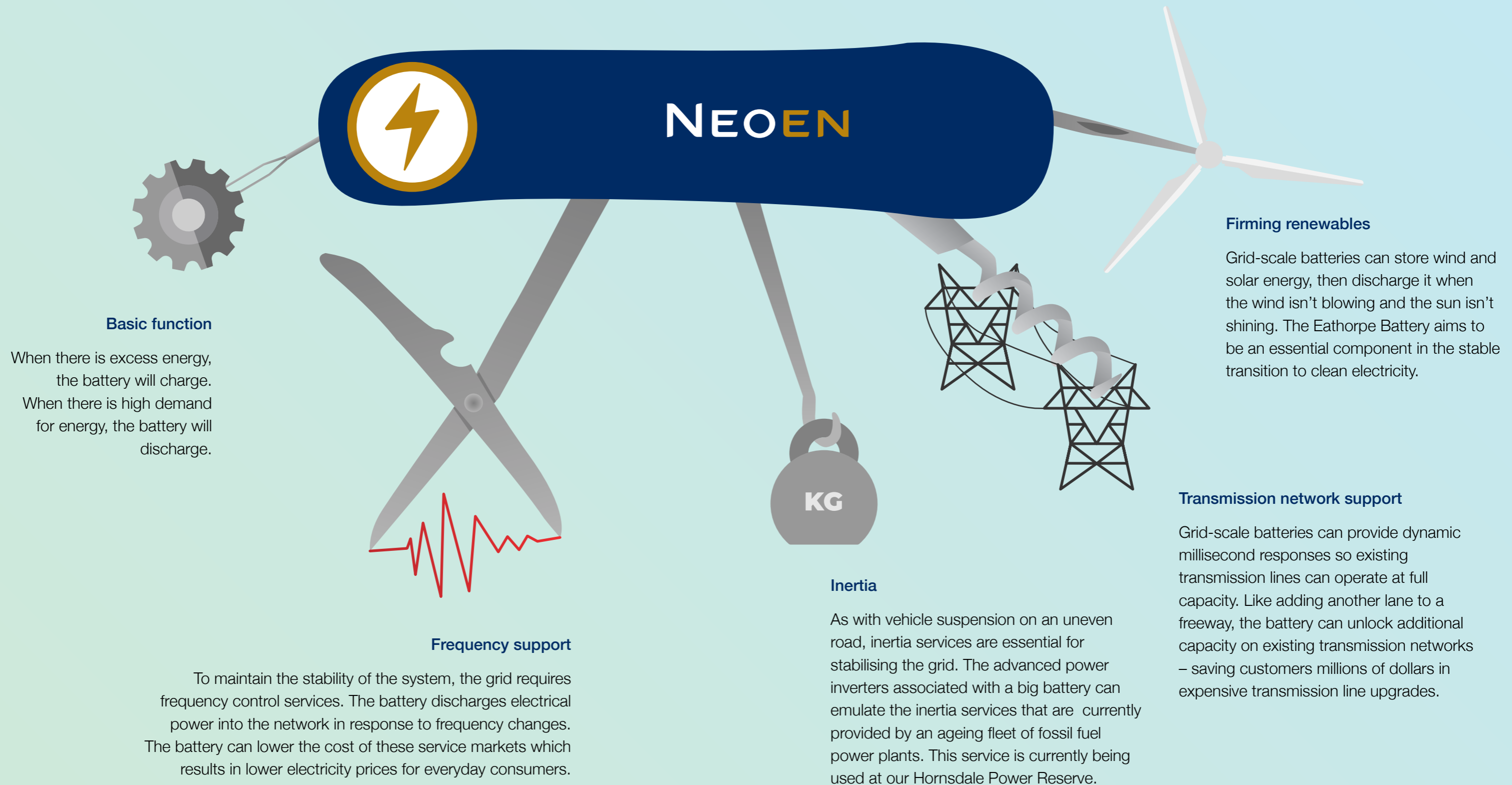

NEW ENGLAND RENEWABLE ENERGY ZONE (REZ)

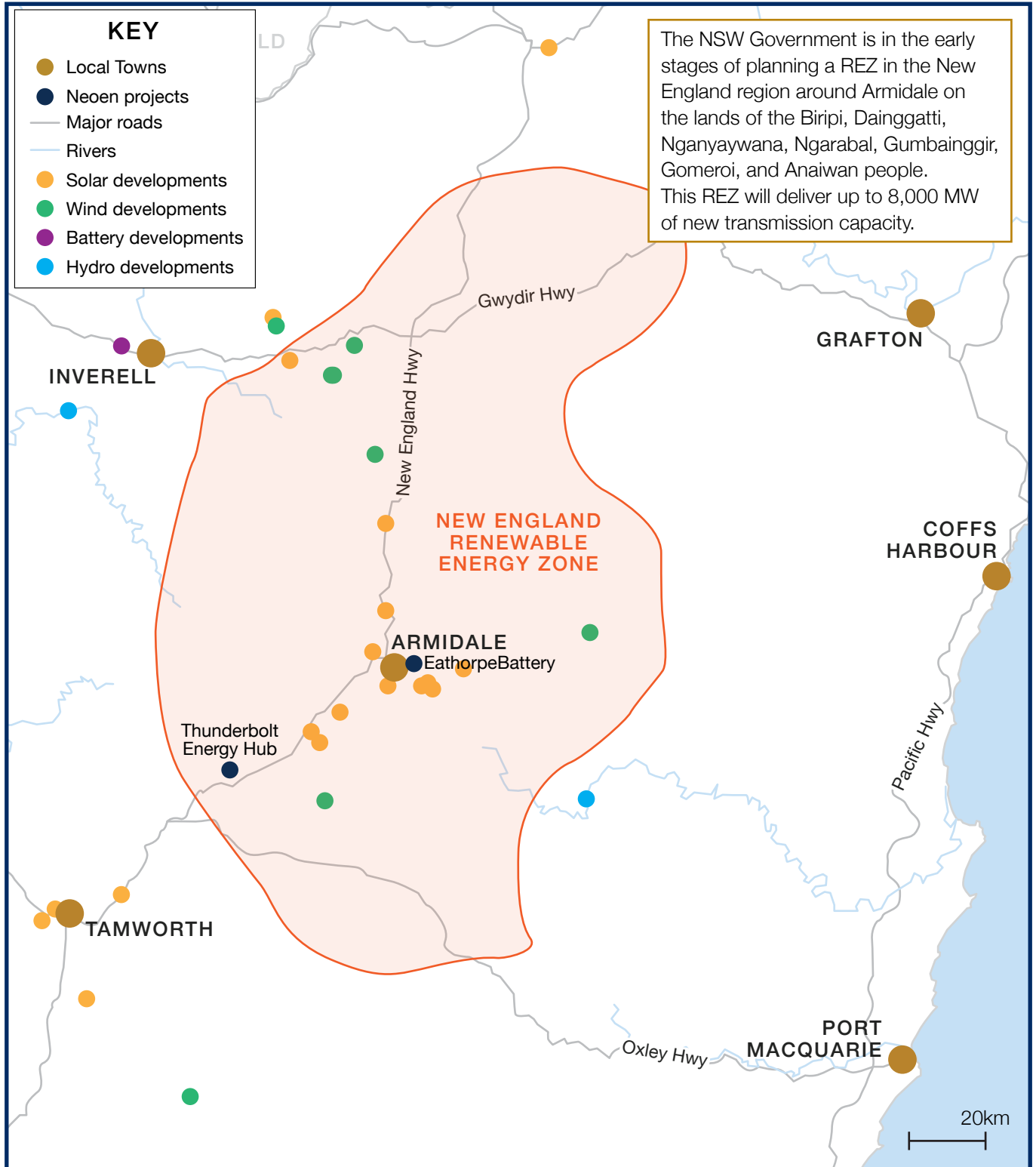

CHOOSING THE SITE

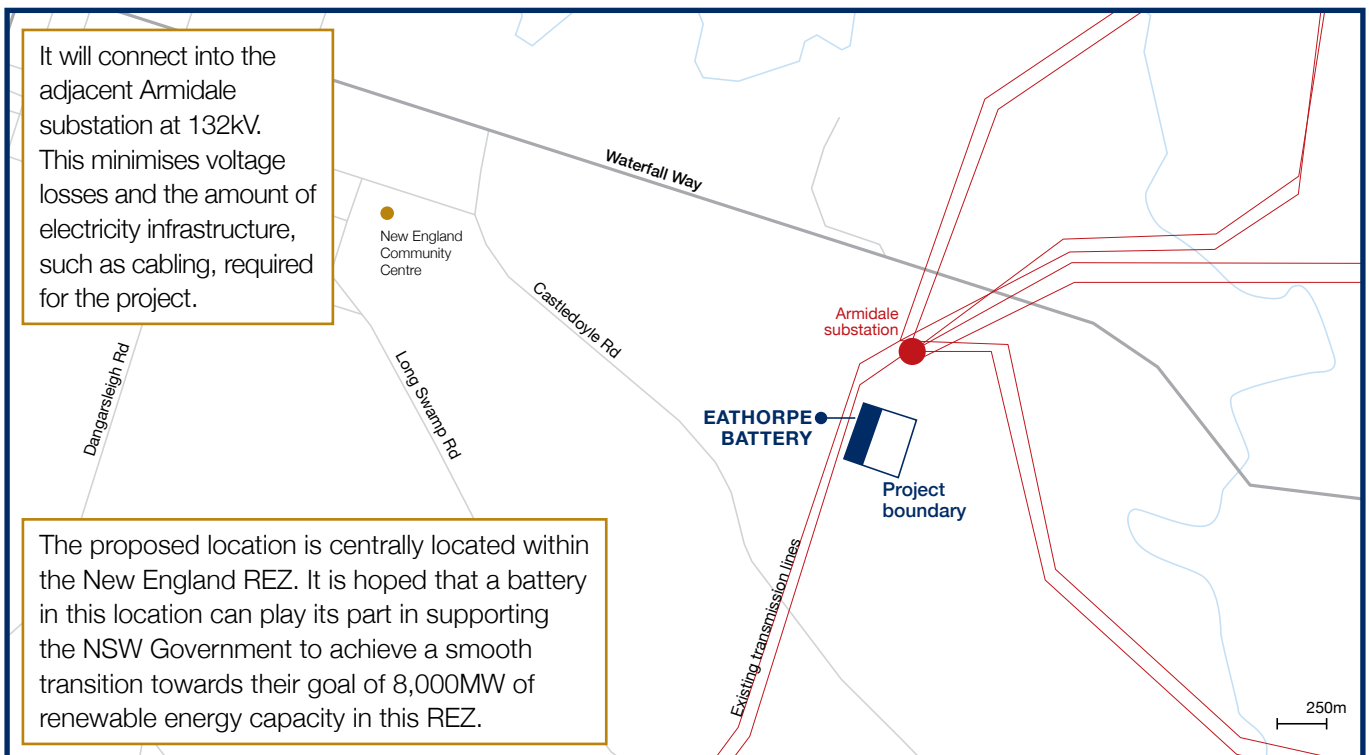
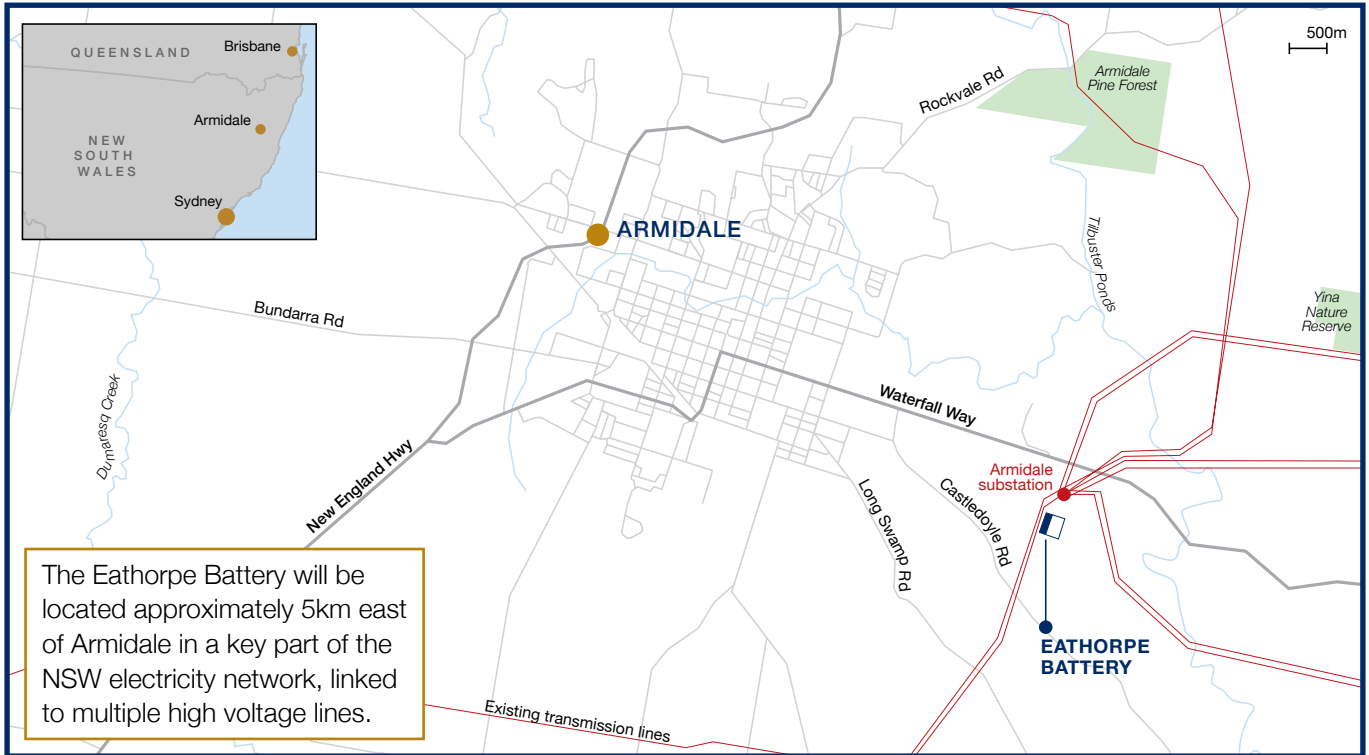

PROPOSED PROJECT LAYOUT

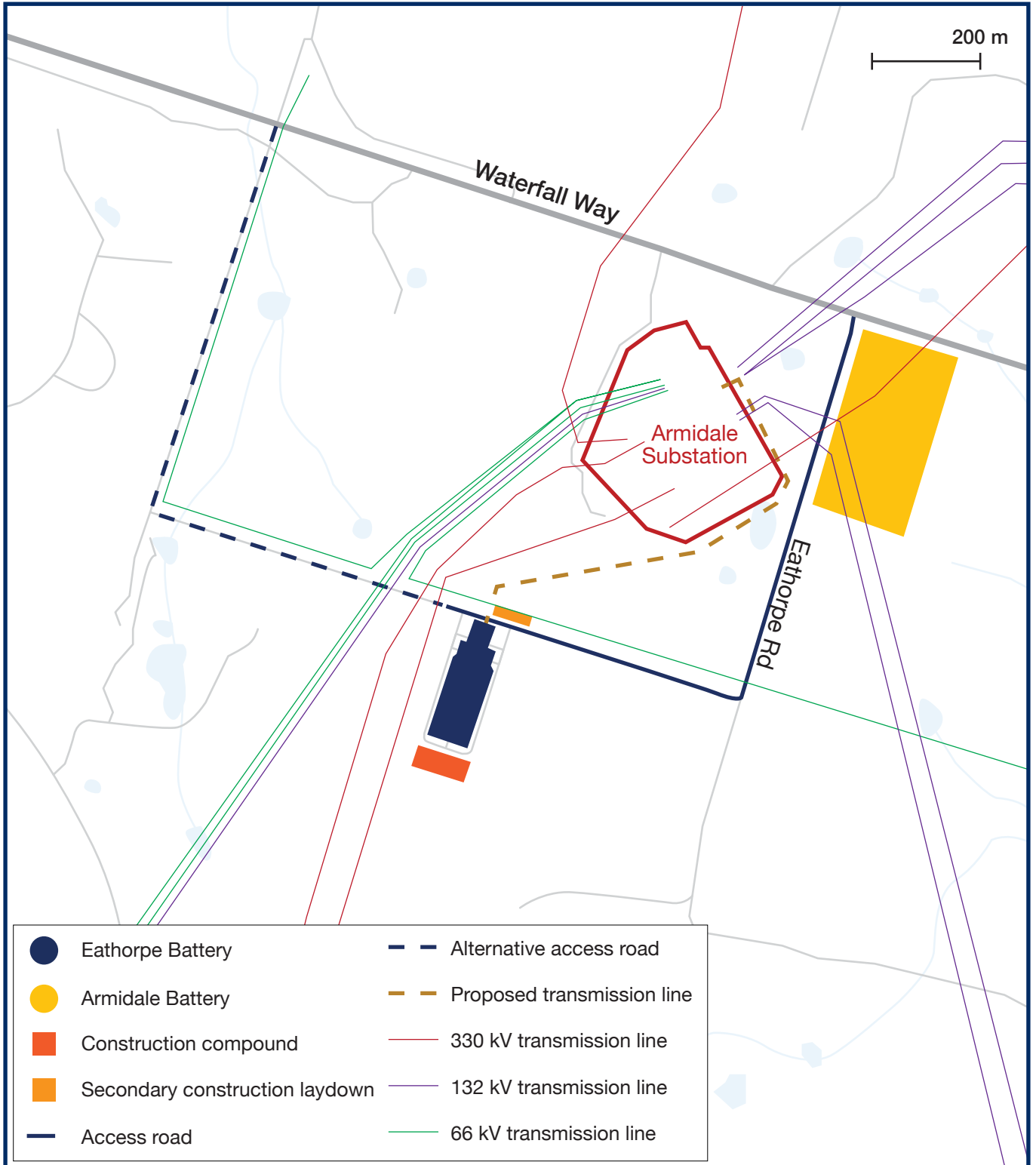

PROPOSED BATTERY LAYOUT

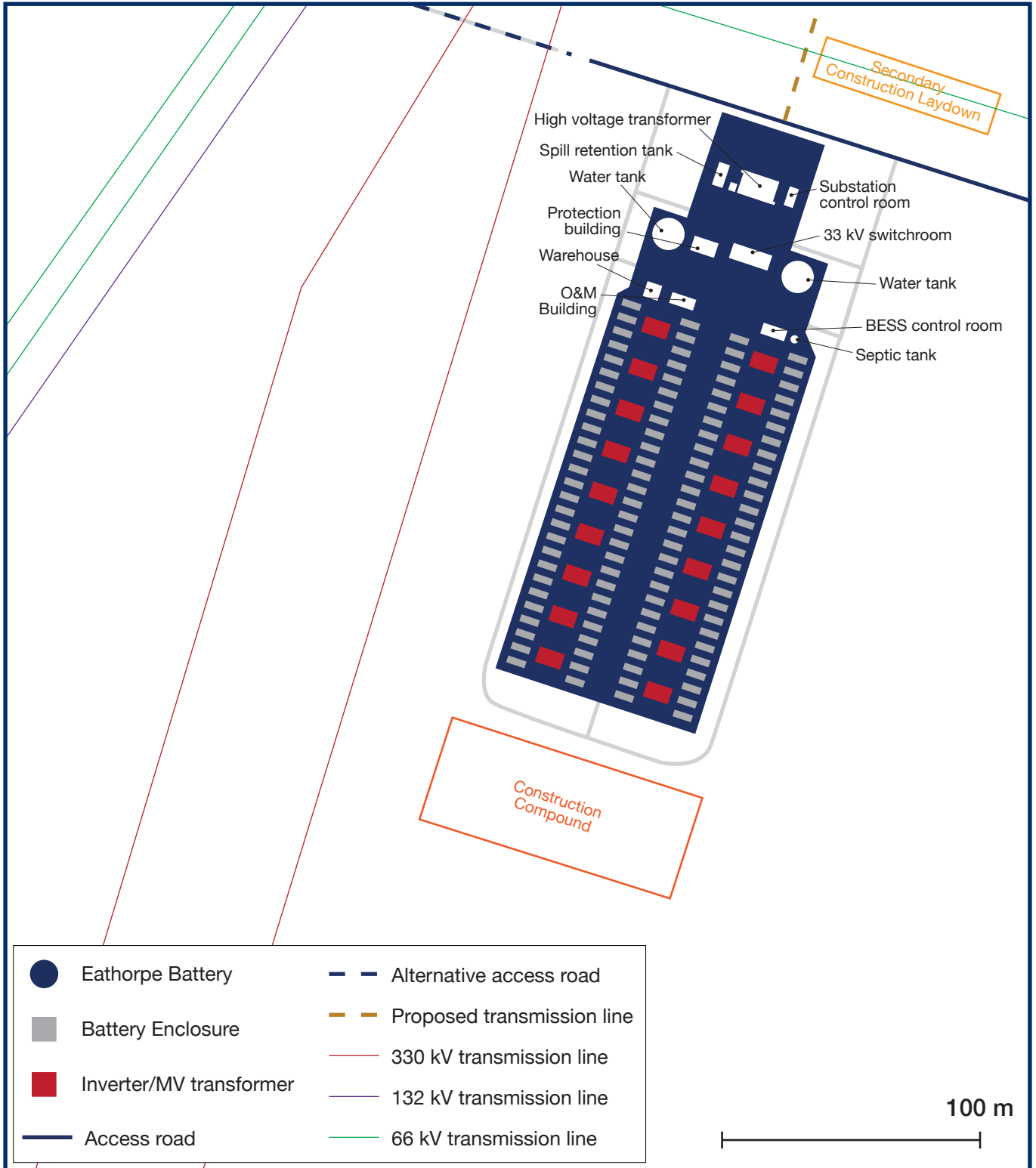

PROJECT LIFECYCLE

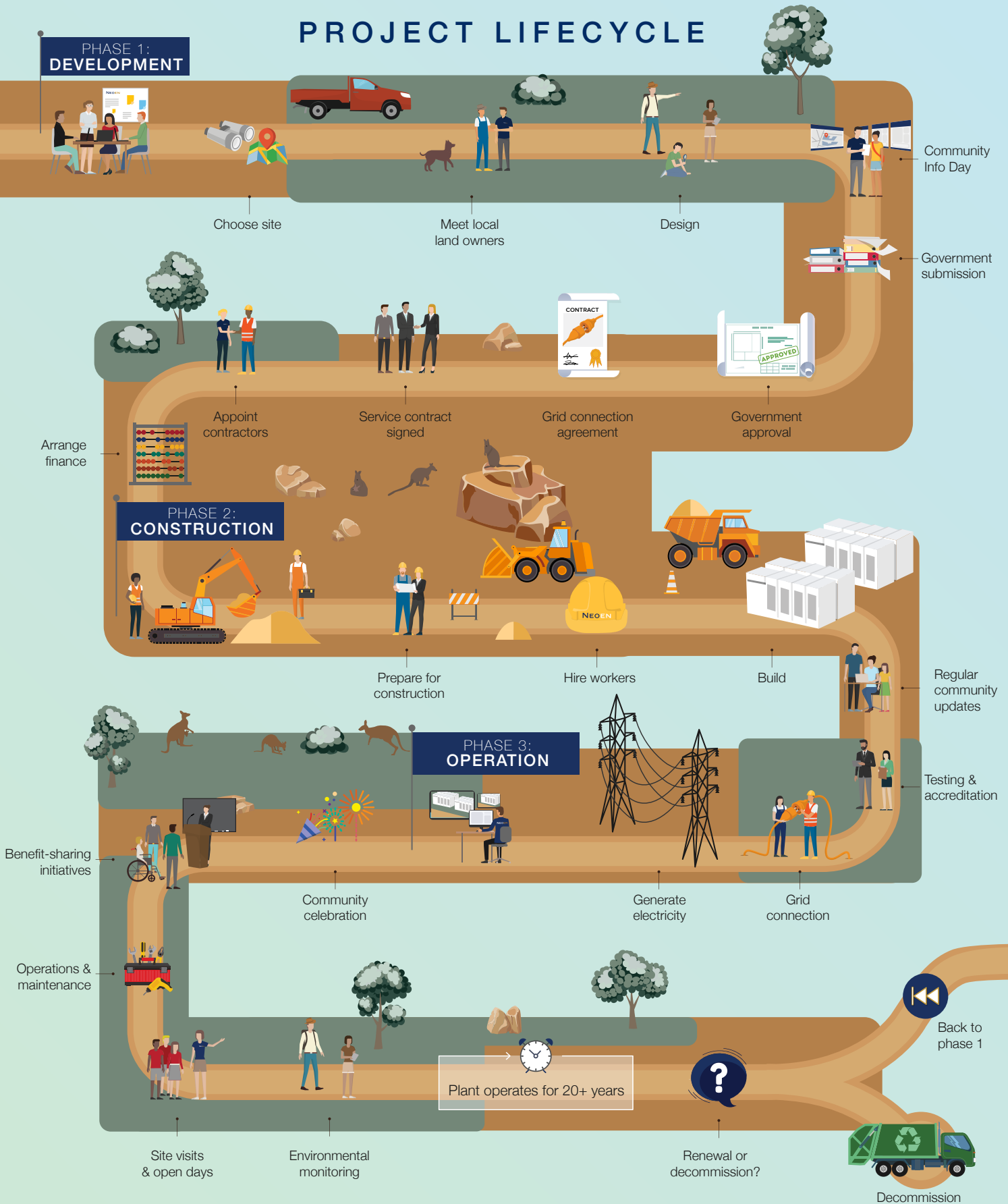

COMMUNITY BENEFIT-SHARING

Some of your ideas so far:



Community benefit fund

The funds would be allocated to local community projects through a competitive annual grants process.



Educational resources

Develop educational resources for local schools to support learning about renewables and our future energy system.



Local tourism

Develop a local tourism initiative centred on batteries or renewable energy.



Tell us your ideas

We'd like to hear your ideas on community benefits:
surveymonkey.com/r/eathorpebattery

NEOEN

Learning Hub

Take your students on a journey of discovery into the wonders of electricity and renewable energy

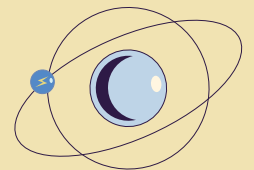

neoenlearning.com

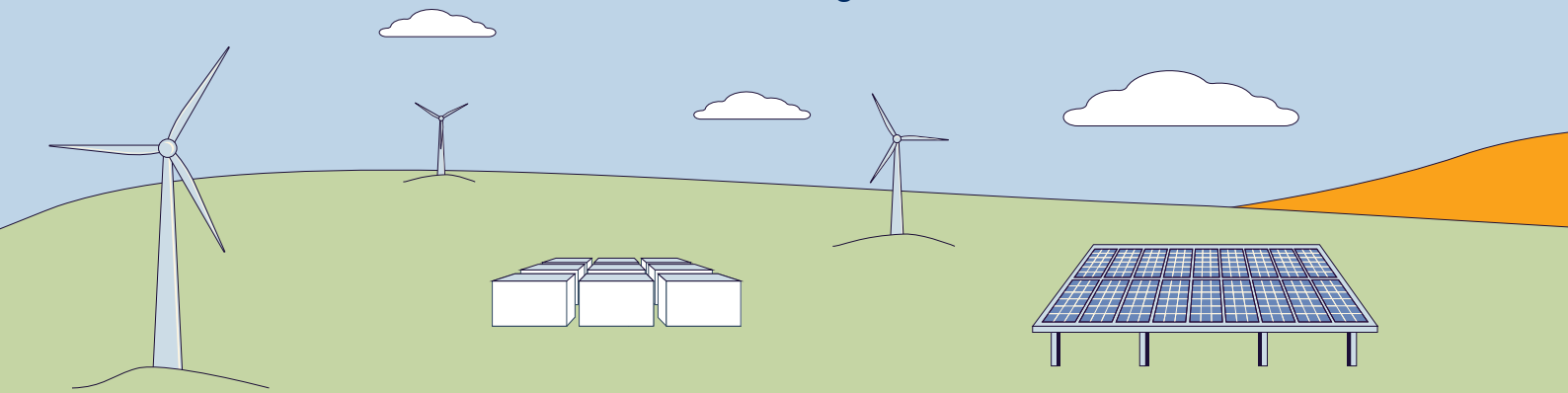

ABOUT STORAGE

Q1. What technology is being used for the project?

The Eathorpe Battery will utilise lithium-ion units and associated equipment from leading manufacturers. These manufacturers are selected through a separate competitive tender process.

In principle, the facility will be an orderly arrangement of battery cabinets, inverters and control systems including electrical and data cabling. The battery packs are enclosed in custom designed, dust and waterproof 'cabinets' made of steel. The cabinet colour is white or light coloured to assist with heat management and each cabinet has its own internal thermal management system.

Q2. How big will it be?

Once completed, the 100MW battery will cover around 3 hectares of land. It will be no higher than 2.5 meters.

Q3. What are the benefits of battery energy storage?

In making the transition from fossil fuels to 'baseload' renewables, the ability to store and dispatch energy will play a key role. Pumped hydro is an example of longer-term storage; that is, suitable for storing energy and releasing it over days or weeks. However, pumped hydro has a relatively slow 'ramping' time and is less suitable for providing rapid-response services to grid contingency events such as outages or heat waves (with high demand created by air-conditioning). Battery storage, such as Tesla's lithium-ion Powerpack technology, fills this key short-term role.

These are some of the functions a grid-scale lithium-ion battery may be expected to perform:

- Network security services including Frequency Control Ancillary Services and Network Loading Control Ancillary Services
- System Restart Ancillary Services
- Arbitrage (spot market trading)
- Peak shaving
- Block/load shifting
- Renewable firming and smoothing.

The NSW Government is committed to renewable energy and has set ambitious goals with the new Electricity Roadmap. The Eathorpe Battery aims to support the effort of the NSW Government in achieving its renewable vision.

Q4. What is the life cycle of the Eathorpe Battery?

Current battery technology comes with an industry-leading 15-20 year warranty. The batteries still retain most of their capacity at this time, and will be able to operate beyond it depending on market conditions and other factors.

Q5. How is the battery reducing costs for consumers?

Battery storage can reduce costs for consumers in 3 ways:

- Supporting more wind and solar, which are now the cheapest forms of power
- Increasing competition in ancillary markets and pushing electricity prices down
- Helping to avoid blackouts and the associated costs.

Q6. What happens to the batteries when they reach the end of their life?

We make a commitment that all above-ground infrastructure is removed and the site rehabilitated when a project ceases to operate. After removal, most of the material in the batteries is reclaimed or recycled with over 60% recovered for re-use.

HEALTH & CULTURE

Q7. Are there any health risks?

The Eathorpe Battery is using similar technology to the batteries that are increasingly installed in homes, just on a larger scale. There are no known health risks associated with properly maintained large-scale battery installations.

Q8. Is the project reducing air quality?

Monitoring of dust levels during construction is a basic requirement of each project. Dust generating activities are assessed during windy conditions and are stopped and rescheduled where adequate control of dust generation cannot be achieved.

Visual observation of machinery is undertaken during site inspections as well as daily pre-start checks which ensure all machinery has appropriate emission control devices, is in good working order, and is maintained correctly.



NOISE

Q9. What components make noise in a battery?

When the battery operates, there are a few components that can make noise. The noise may not be constant, but vary based on the temperature and how the battery is working. The times of highest noise are likely to be experienced could be late summer afternoons when the battery requires most cooling, or during cold winter mornings when heating is required.

The components that typically make noise in a battery are:

- **Battery fans and the cooling/heating system:** noise is emitted from fans when they spin, predominantly during the hot summer months to keep the electronic components of the battery cool. Similarly, the cooling/heating system makes noise during summer and winter months. This cooling/heating system operates in a similar way to a household air-conditioning system and makes similar sounds to a household system.
- **Transformers:** The battery draws power from the transmission lines and also sends power to the transmission lines into the National Electricity Market (NEM) as required to support the network. The process of transferring electricity between the battery and the transmission lines requires a change in the voltage, from low (at the battery) to high (at the transmission lines). Transformers are responsible for the change in voltage. They can make a gentle humming sound. Large transformers use fans to cool as well, which generates noise.
- **Inverters:** Inverters are responsible for converting direct current (DC) into alternating current (AC), which is utilised by the transmission lines. Inverters used for a battery are very similar to inverters installed as part of a domestic rooftop solar installation, converting the DC power produced by solar panels to AC power injected into the electricity grid. The sound made by battery inverters is similar to the sound made by a household solar inverter.

Q10. What noise limits are there?

The noise limit at night-time is 35 decibels (dB) at a neighbouring dwelling.

To provide an indication of how noisy different sound levels are, Neoen have included a comparison table of typical sound levels of different sources as published by Safe Work Australia¹. A 30dB sound level is equivalent to whispering, while a 40 decibels (dB) sound level is equivalent to quiet radio music.

Sound Source	Typical Sound Level (dB)
Hearing threshold	0
Whispering	30
Quiet radio music	40
Normal conversation	60
Loud conversation	70
Kerbside heavy traffic	80
Front-end loader	85
Lawn mower	90
Sheet metal workshop	100
Chainsaw	110
Rock drill	120
Rivet hammer	130
Jet engine at 30 m	140

Table 1 – Typical sound levels for various sound sources

Q11. What mitigation measures can be implemented to reduce battery noise?

There are a number of things that can be done to mitigate noise, including:

- **Battery design:** battery manufacturers are continuously improving the battery technology to make their components quieter in their operation.
- **Screening:** sometimes screening measures may be employed surrounding the battery as required. Screening can include vegetation screening or a noise wall.
- **Placement within large buildings:** very large buildings are a possible alternative to outside ingress protection (IP) rated cabinet type enclosures for housing big batteries. This approach may be suitable or unsuitable for a given battery site depending on the battery size, location, fire hazard risk assessment and visual impact.

Q12. What work do we do to understand the impacts?

Neoen is undertaking a number of activities to better understand noise impacts, including:

- Working with battery manufacturers on their battery designs and layouts to minimise noise
- Studies with independent noise consultants for each battery site during development
- Monitoring of operating projects to ensure that we meet our obligations.

1 Safe Work Australia – Noise: www.safeworkaustralia.gov.au/safety-topic/hazards/noise

EATHORPE

BATTERY



eathorpebattery.com.au



Joanna Murphy, Project Manager



contact@eathorpebattery.com.au



1800 966 020